

September 2013

**APPLY PESTICIDES CORRECTLY  
A GUIDE FOR COMMERCIAL APPLICATORS**

**Industrial, Institutional,  
Structural and Health  
Related Pest Control**



**U. S. ENVIRONMENTAL PROTECTION AGENCY  
OFFICE OF PESTICIDE PROGRAMS  
WASHINGTON, D. C. 20460**

This leaflet was edited by Charles Nagamine for the Pesticide Applicator Training course study packet. The Pesticide Applicator Training Program's office is located on the Manoa campus of University of Hawaii in St. John 017; telephone 956-2005. The mailing address is: Dept. of Environmental Biochemistry; 1800 East-West Rd., #329; Honolulu, HI 96822. The Cooperative Extension Service, part of the U. H. College of Tropical Agriculture and Human Resources, sponsors of Pesticide Applicator Training Program.

# TABLE OF CONTENTS

	Page		Page
Acknowledgments .....	1	Wood-Destroying Pests .....	9
Preface .....	1	Termites .....	9
Introduction .....	2	Powder-Post Beetles .....	10
Using Pesticides Safely .....	2	Long-Horned Beetles .....	11
General Insect Pests .....	2	Wood Decay Fungi .....	11
Cockroaches .....	2	Stored Product Pests .....	11
Ants .....	3	Grain and Flour Beetles .....	11
Bees and Wasps .....	4	Cabinet Beetles .....	12
Parasitic Pests of Man .....	5	Indian Meal Moth .....	12
Bed Bug .....	5	Angoumois Grain Moth .....	12
Fleas .....	5	Grain Weevils .....	12
Ticks .....	5	Vertebrates .....	12
Mosquitoes .....	6	Rodents .....	12
Occasional Invaders .....	6	Birds .....	13
Clover Mite .....	6	Bats .....	14
Millipedes .....	6	Skunks .....	14
Flies .....	7	Squirrels .....	14
Silverfish and Firebrats .....	7	Moles .....	14
Booklice .....	8	Snakes .....	14
Spiders .....	8	Weeds .....	14
Fabric Pests .....	8		

## ACKNOWLEDGMENTS

This guide has been developed by Purdue University under U.S. Environmental Protection Agency (EPA) contract number 68-01-3117. This contract was issued by the Training Branch, Operations Division, Office of Pesticide Programs, EPA. The leader of this group effort was Gary W. Bennet, Purdue University. Editors were Mary Ann Wamsley, EPA, and Donna M. Vermeire, North Carolina State University.

### Contributors were:

Joel R. Meltzner, Environmental Protection Agency,  
Washington, D.C.

Harry B. Moore, North Carolina State University

Vernon E. Walter, Terminix International, Inc.,  
Memphis, Tennessee

Eugene D. Young, California State Polytechnic  
University

## PREFACE

Federal regulations establish general and specific standards that you must meet before you can use certain pesticides. Your State will provide material which you may study to help you meet the *general* standards. This guide contains basic information to help you meet the *specific* standards for applicators who are engaged in industrial, institutional, structural and health-related pest control.

Because the guide was prepared to cover the entire nation, some information important to your State may not be included. The State agency in charge of your training can provide the other materials you should study.

This guide will give you information about:

- pest control and pesticides,
- using pesticides safely, and
- recognizing and controlling common pests.

## INTRODUCTION

Proper identification of pests and a knowledge of pest development and behavior are keys to effective pest control. After you have identified the pests, you must decide how to control them. Removal of food, water, and habitat (place in which to live) is an important part of effective pest control, but should be combined with appropriate chemical and mechanical control methods. If you choose to use a pesticide, select a product that has label directions for the intended use.

The various formulations can be used on a wide variety of jobs in many different types of equipment. But each formulation has its own characteristics which help determine which is the best to use in a given situation. For example:

- for a space spray, you might use an insecticide in oil;
- for long residual activity in a dry situation, a dust;
- for a residual spray, either an oil solution or water emulsion;
- for a surface application of a residual where appearance is not too important, a wettable powder spray;
- for use around open flames and heat, an emulsion;
- for use around electrical installations, an oil solution;
- for spraying on or around plants, a wettable powder or selected emulsion;
- for use on or around linoleum, rubber, asphalt floor tiles, and some synthetic fibers, a water-base insecticide.

## USING PESTICIDES SAFELY

Do not release pesticides into soil, air or water except where you intend to do so as a safe and approved part of your work. Pesticides put in the wrong place, or on the wrong plant, or where the wrong animal can contact or consume them are pollutants and may cause serious harm.

Use special care in sensitive areas such as food handling establishments and where children, elderly people or ill people are located. Pets and their eating places also must be kept in mind. Pesticides used in or around such areas should be the safest

ones available that are effective. Apply them so that contamination does not occur.

## GENERAL INSECT PESTS

### COCKROACHES

Four species of cockroaches are commonly found throughout the United States. They vary somewhat in appearance and habits but in general are all flat, brownish or dark, and fast-running. Cockroaches seek cover in the daytime or when disturbed at night. They may be carried into buildings in boxes and beverage cases, and with groceries. In apartments and larger buildings, they readily migrate from one room to another along water pipes, cracks in the walls, and wall voids. Some species may enter structures from outdoors or come in through sewer lines.

The stages in the life cycle of a cockroach are:

- the egg, enclosed in a capsule which contains several eggs,
- several stages of nymphs, which look like the adults but are smaller and have no wings, and
- the adult.

#### German Cockroach

- A common species found in kitchens.
- Adults are about  $\frac{1}{2}$  inch long.
- Tan with two dark stripes running lengthwise on the area just behind the head.
- Often occur in large numbers.

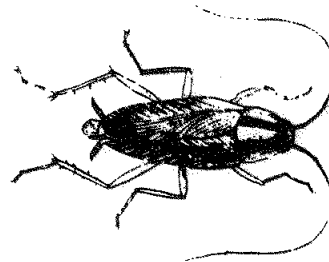

#### American Cockroach

- Reddish-brown; margins of prothorax (behind head) lighter.
- Largest of the common cockroaches (adult about  $1\frac{1}{2}$  inches long).
- Found in dark, moist areas such as basements, sewers, and steam heat tunnels.

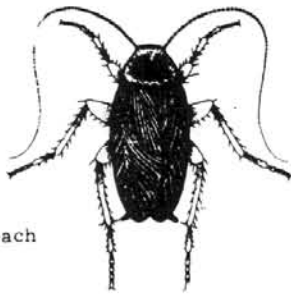

American Cockroach

### Oriental Cockroach (not established in Hawaii)

- About 1 inch long as an adult.
- Shiny black or very dark brown.
- Female has small wings; wings of the male cover about  $\frac{3}{4}$  of his abdomen.
- Often found in damp places such as basements. May enter buildings through sewer openings.
- May live outdoors during the summer months and move from building to building.

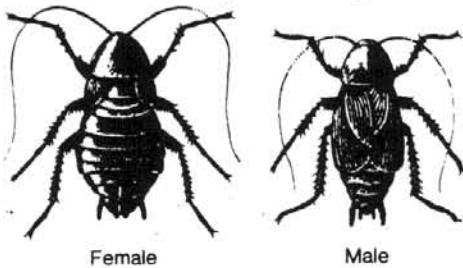

Female

Male

### Brown-Banded Cockroach

- About  $\frac{1}{2}$  inch long.
- Brown with two lighter bands across the base of the wings and abdomen.
- May infest an entire building.
- Infestations usually start from luggage, furniture, or other materials shipped from one place to another.

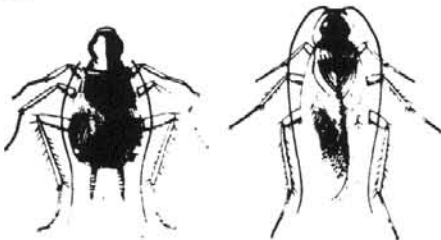

In some areas of the country, there are other cockroach pests. Some of these are very similar in appearance to those described above but differ in their habits. As a result, proper identification is essential to control. Contact local experts for information on other species that may be important. The removal of food and water sources and destruction of breed-

ing places is essential in obtaining satisfactory cockroach control.

In kitchens and living areas, apply insecticides as crack and crevice or spot treatments to places where the insects hide. Label directions of residuals permit only crack and crevice treatment to be used in commercial food handling areas. Common "hide-outs" are behind and beneath built-in shelves and cabinets, in and beneath stoves and refrigerators, under sinks, and behind baseboards.

In basements, cockroaches hide beneath trash, in cupboards and washing machines, and in cracks and crevices in concrete, brick, or block walls. Sprays are usually preferred to dusts because they are easier to apply and the residue is not as visible. Dusts, however, can sometimes be blown into places difficult to reach with spray.

Use ULV (ultra low volume) and aerosol applications of contact sprays and flushing agents to supplement residual sprays and dusts. Use them alone where the label prohibits use of residuals.

### ANTS

The stages in the life cycle of an ant are:

- egg,
- larva,
- pupa, and
- adult.

During the year, ant colonies produce winged individuals. These are often mistaken for termites.

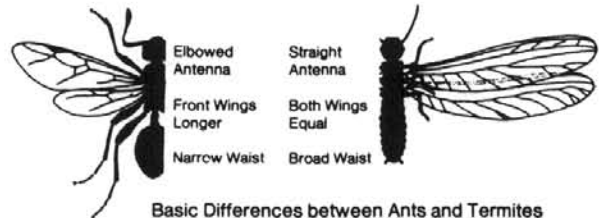

Basic Differences between Ants and Termites

### Carpenter Ants

- Variable in size, measuring up to  $\frac{1}{2}$  inch long.
- Red to black.
- Either winged or wingless.
- Build nests in hollow trees, logs, telephone poles, posts, porch pillars, and other wood used in homes.
- A small pile of coarse sawdust beneath wood with a higher than normal moisture content is a common sign.

- Do not eat wood but simply hollow it out to form nests.
- Can weaken structures.

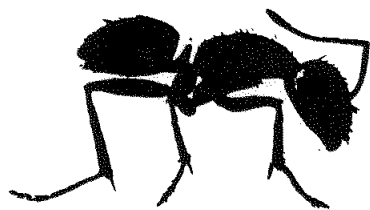

Carpenter Ant

## Other Ants

- Most build their nests in soil.
- Those that invade buildings usually nest near foundation walls, in lawns, or under concrete slabs.

Control both carpenter ants and other indoor- or outdoor-nesting ants by direct treatment of the nests. Locate the entries of carpenter ants. Then blow an insecticide dust into the nesting area. Control other ant species with sprays, dusts, or granular insecticides directed at the nest and surrounding area. Baits may be used effectively.

If you cannot locate the nest site, apply insecticides where the ants gain entry or hide—along foundation walls; at doorways, windowsills, and baseboards; behind built-in cabinets and furniture; or beneath refrigerators and other heavy appliances.

## BEES AND WASPS

Bees and wasps are nuisances and may be dangerous to man because of the female's ability to sting. These insects have similar life cycles, including:

- egg,
- larva,
- pupa, and
- adult.

## Paper Wasps

Paper wasps include the single comb (*Polistes*) wasps, hornets, and yellow jackets. Single comb wasps build open comb nests under eaves of houses, in shrubs, and in other protected places. Hornets' nests are large, covered, grayish-brown paper structures usually seen hanging in trees or bushes. Yellow jackets often build their nests above as well as underground. These wasps vary in color. As a gen-

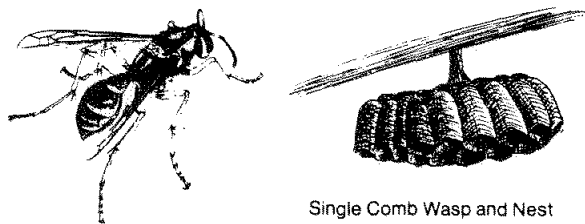

Single Comb Wasp and Nest

eral rule, the hornets are largest (about 1½ inches long), the single comb wasps are intermediate in size (about 1 inch) and the yellow jackets are smallest (about ¾ inch).



Yellow Jacket

Special protective clothing is needed when controlling paper wasps. Insecticide sprays work well, but they must be applied at night with a sprayer large enough to do the job quickly without getting too close to the nest. Dusts may be blown into the nest openings of hornets and yellow jackets. Baits are also available for use against some species of wasps.

## Solitary Wasps

Solitary wasps may dig holes in lawns or bare earth to build their nests. **The cicada killer:**

- is a black and yellow wasp about 1½ inches long,
- will not sting or otherwise cause harm (only the males buzz around people), and
- can be controlled by directing dusts or sprays at the entrance to its burrow.

## Mud Dauber Wasps

These wasps:

- are so named because they construct their nests of mud in protected places,
- are usually black with yellow markings,
- are not dangerous since they do not aggressively defend their nests,
- can be eliminated simply by tearing down their nests.

## Bees

Bees such as the **honey bee**, **bumble bee**, and **carpenter bee** are pests in and around buildings. Structural damage results from their nest-building activities. The bumble bee, however, is not established in Hawaii.

Honey bees may build nests in walls, chimneys, and attics. Their combs may melt and allow honey to seep through walls. In addition, the combs may be infested by other insects.

Bumble bees build their nests in the ground, in straw or rags, or in buildings.

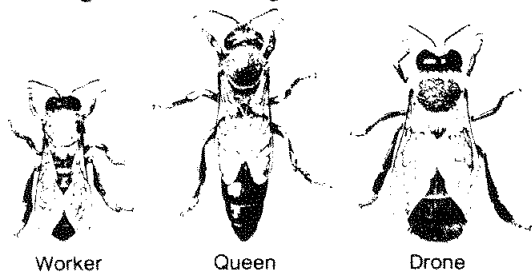

Three Castes of Honey Bees

Carpenter bees drill  $\frac{1}{2}$  inch holes into exposed wood. The holes make a 90-degree turn below the surface and run with the grain of the wood for distances up to 12 inches.

Bumble bees and carpenter bees look very much alike. Bumble bees, however, have yellow hair on the top of the abdomen.

Control bees by directing insecticides at the nest. It is wise to wear clothing to protect against stings when treating nests of honey bees and bumble bees.

## PARASITIC PESTS OF MAN

Many insects, such as **bed bugs**, **fleas**, **ticks** and **mosquitoes**, feed directly upon man and other warm-blooded animals. In addition to their bloodsucking activities, many are able to carry disease-causing organisms from one animal to another or to man.

### BED BUGS

- Prefer man as their host.
- Hide in cracks and crevices and come out to feed in the dark, usually as the host sleeps.
- Adults are about  $\frac{1}{4}$  inch long, reddish-brown, with oval, flat bodies.

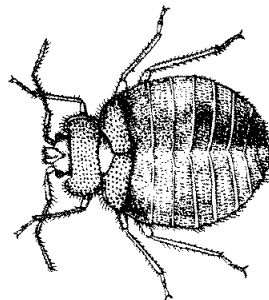

Bedbug

The stages in the life cycle of a bedbug are:

- the egg, glued inside cracks and crevices,
- nymphs, and
- the adult.

Either sprays or dusts can be used for control. Dusts are preferred behind baseboards, window and door casings, and in other cracks and crevices. Do not treat surfaces that will come in direct contact with humans. Treat tufts and seams of mattresses and cover them with sheets after the spray has dried.

### FLEAS

Fleas are small insects without wings.

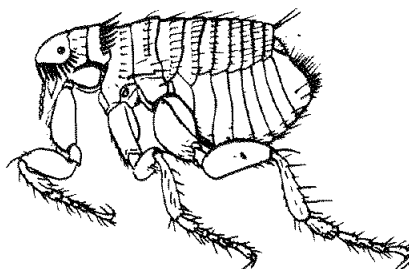

The stages in the life cycle of a flea are:

- the egg,
- larva,
- the pupa, and
- the adult.

Flea infestations in homes are usually noticed after a host animal (usually a cat or dog) has been removed. Adult fleas that develop from eggs laid earlier begin to bite people in the absence of normal hosts. Eggs may hatch over several months.

Control fleas in structures by using surface and crack and crevice sprays. Control them on animals by using dips, sprays, flea collars, or dusts. The pest control specialist can treat the premises; however, the pet should be treated by the owner or by a veterinarian.



## TICKS

A number of ticks are parasites of man and other animals.

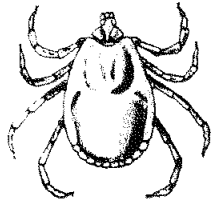

Hard Tick

The stages in the life cycle of a tick are:

- egg,
- six-legged larva,
- nymph (or nymphs), and
- adult.

The **brown dog tick:**

- is a common household pest,
- may be found on other animals, although the main host is the dog,
- will drop off the host after feeding and conceal itself in any available crack or crevice such as behind cove moldings and window frames and in furniture.

This tick is difficult to control because of its many potential hiding places. Eggs may hatch over a period of up to 5 months. Hiding places may need to be sprayed at monthly intervals to eliminate this tick. The owner or a veterinarian should treat dogs, using dips, sprays, or dusts.

## MOSQUITOES

- May occur in large numbers in the warm-weather months.
- Adult females feed on warm-blooded animals and birds.
- May develop in standing water.

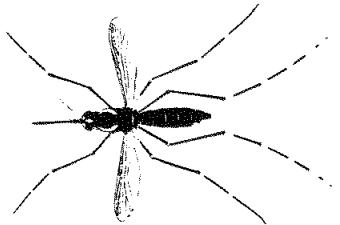

The stages in the life cycle of a mosquito are:

- the egg, which may be laid on water or in areas which later will be flooded, depending on the species,

- larva, found only in water,
- the pupa, also found only in water, and
- the adult.

Effective control requires community-wide efforts. Elimination of all mosquito breeding habitat is essential. Control mosquitoes in smaller areas for a limited time by using sprays, aerosols, or fogs.

## OCCASIONAL INVADERS

The term “occasional invaders” includes those pests which may occur in buildings at some stage of their life cycle, but which do not usually complete the entire life cycle within the building.

### CLOVER MITE

- Is an annoying household pest, especially in housing developments where turfgrasses are newly established and there is a heavy growth close to foundation walls.

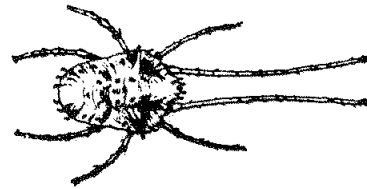

Stages in the life cycle of a clover mite are:

- the egg—laid in foundation cracks and other protected places,
- larva,
- nymph, and
- adult.

Clover mites are difficult to control. Methods that keep the mites from getting indoors give the best results. These methods include:

- establishing a plant-free strip 18 to 24 inches wide along foundation walls and directing pesticide sprays at the strip and walls, or
- if a plant-free strip cannot be established, spraying the foundation walls and the adjacent 10-foot strip of grass.

### MILLIPEDES

- Are gray or brown cylindrical worms  $\frac{1}{2}$  to  $1\frac{1}{2}$  inches long.

- Have two pairs of short legs on each body segment.
- Curl up when disturbed.
- Are common on the forest floor, in compost piles, and in heavily mulched areas.

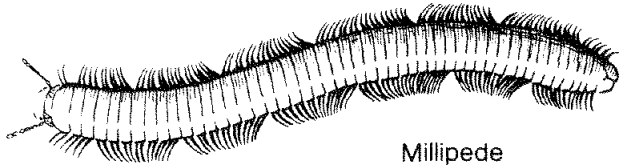

Millipede

The stages in the life cycle of a millipede are:

- egg,
- nymph, and
- adult.

When millipedes leave their natural habitats, they crawl over lawns and sidewalks and may invade buildings in large numbers. They cause no damage.

Prevent invasion by removing leaves and compost around buildings and by sealing cracks in foundation walls and around doors, basement windows, crawl spaces, and vents.

Spraying a 10-foot wide strip around the foundation is helpful in control. Repeat applications may be necessary during periods of heavy migration.

## FLIES

Several species of flies may be found in and around structures.

The stages in the life cycle of a fly are:

- the egg, deposited in a moist place,
- larva,
- pupa, and
- adult.

### Filth Flies

The more common of these are the **house fly** and the **black blow fly**. The black blow fly is slightly larger than the house fly and is a shiny black or green. These flies are annoying and also may carry diseases of man.

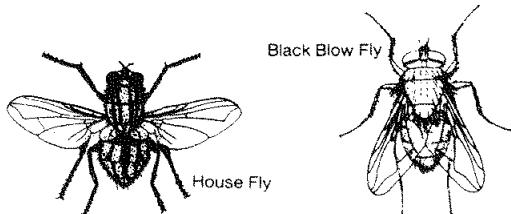

Successful fly control must include a combination of sanitation, physical barriers (such as screens), and insecticides. Garbage, manure, and decaying plant and animal material must be removed. Control adults by spraying resting places. Baits can also be used. Impregnated resin strips can be used in some indoor situations.

Control of adult filth flies around livestock and poultry feeding operations requires the cooperation of the pest control specialist, the livestock producer, and the county sanitarian.

### Cluster Fly

- Often a pest indoors, buzzing around and collecting in large numbers in light fixtures and at windows on warm, sunny days.
- Slightly larger than the house fly and more sluggish.
- Adults seek protected places such as wall voids and attics to spend the winter.
- Screens are ineffective since the flies prefer to crawl in through small openings elsewhere.
- On warm days, they enter rooms through window pulley holes, around baseboards and through other small openings.

Control is difficult. If possible, close all openings through which the flies can enter. Apply sprays and dusts to surfaces where flies are frequently seen and, where possible, into wall voids and other confined spaces where the flies may be. In unventilated areas, impregnated resin strips are effective.

## SILVERFISH AND FIREBRATS

Silverfish and firebrats are wingless insects about ½ inch long as adults. They have three long “bristletails” at the end of their body.

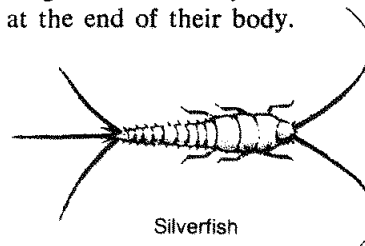

Silverfish

The stages in the life cycle of silverfish and firebrats are:

- the egg,
- young, and
- adult, which continues to molt throughout its life span.

They feed on stored foods, paper, and almost anything containing proteins or carbohydrates. Directed sprays applied to cracks and crevices that serve as hiding and resting places are most frequently used for control; dusts and baits may also be used.

## BOOKLICE

Booklice (psocids) are very small ( $\frac{1}{20}$  to  $\frac{1}{10}$  inch), light-colored insects that may be found indoors and out. Indoors they frequent damp places around stored foods and books and in crawl spaces. They feed on molds and fungi. They do little damage and are pests by being present, often in tremendous numbers.

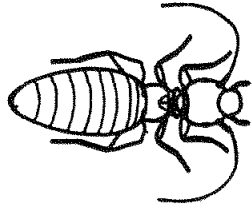

The stages in the life cycle of booklice are:

- egg,
- nymph, and
- adult.

They can be serious pests for manufacturers of food products and containers. Control booklice by removing moisture and food sources. Directed sprays and aerosols are effective in control.

## SPIDERS

Spiders are pests because of their webs. The **black widow** and the **brown recluse (fiddleback)** can seriously injure humans. Neither spider bites unless provoked.

A spider develops from an egg into an immature spider which may molt several times before becoming an adult.

The female black widow is shiny black and distinctively marked with a red or yellow spot on the underside of the body, sometimes in the form of an "hourglass". This spider lives under rocks and boards and in or around buildings.

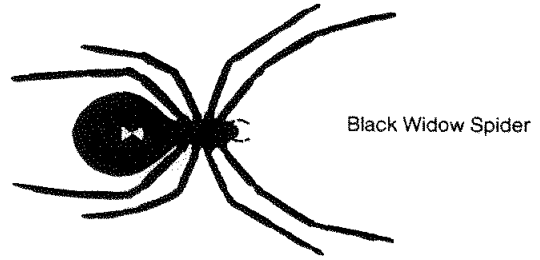

Black Widow Spider

The brown recluse spider is tan to brown with a dark brown fiddle-shaped pattern on the front half of its back. It is usually found in buildings such as barns, sheds, garages, and houses that are dry, littered, undisturbed and contain insects that serve as food. Favorite hiding places seem to be the arms or legs of garments left hanging undisturbed. People are sometimes bitten while sleeping in beds or wearing clothes that have been unused for a length of time.

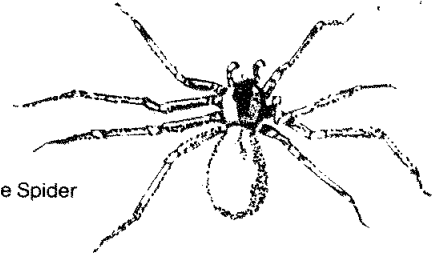

Brown Recluse Spider

Control spiders by controlling insects that serve as food, and by removing webs. Direct pesticide sprays or dusts at hiding areas.

## FABRIC PESTS

Carpet beetles and clothes moths attack a variety of woolen products, furs, feathers, and hair. Infestations are common in boxes of old clothing, overstuffed furniture, woolen carpets, and piano felt. The larval stage causes the damage. The presence of adults in an area may be the first sign of an infestation.

The stages in the life cycle of beetles and moths are:

- egg,
- larva,
- pupa, and
- adult.

### Black Carpet Beetle

- These are the most widespread and damaging of the carpet beetles.
- Adults are shiny black and about  $\frac{1}{8}$  inch long.

- Larvae are up to ½ inch long, yellowish-brown, carrot or cigar-shaped, and have a long brush of tail bristles.

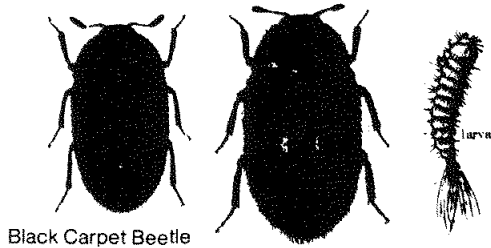

Black Carpet Beetle

### Other Carpet Beetles

- Adults are oval, about ⅛ inch long, and brightly colored in various patterns of white, brown, yellow, and orange.
- Larvae are about ¼ inch long, light brown to black, fuzzy, and slow-moving.

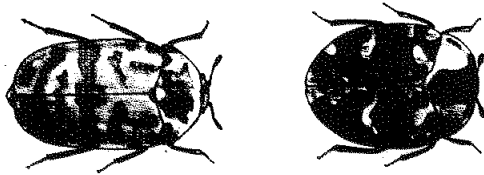

### Webbing Clothes Moth and Casemaking Clothes Moth

The webbing clothes moth adult is buff-colored with reddish hairs on the top of its head. The casemaking clothes moth is light brown and has three dark spots on each wing. The larva of the webbing clothes moth usually spins feeding tunnels of silk as it moves over its food sources. The casemaking clothes moth larva carries with it a small silken case that it spins around itself. To this case are attached bits of the fiber on which the larva is feeding. It attaches the case to walls or ceilings when it enters the pupal stage.

Prevention is a very important part of fabric pest control. This can be done by cleaning fabrics correctly and storing them in tight containers with moth crystals. Control infestations by treating all infested areas with directed sprays.

## WOOD-DESTROYING PESTS

### TERMITES

The stages in the life cycle of a termite are:

- egg,
- nymph, and
- adult.

Termites are social insects having colonies in which there is a division of labor between different types of individuals. Nearly all species have reproductive and soldier castes, and many have a worker caste. If a worker caste is lacking, the nymphs handle the nest building and food gathering activities. These workers are responsible for damage done to wooden structures. Within the reproductive caste are primary reproductives which are winged. They emerge from the colony during the warmer months of the year to disperse and form new colonies.

### Subterranean Termites

- So named because the colony extends below ground with the workers attacking wood above ground.
- White, soft-bodied workers eat the soft grain of wood, leaving a thin shell outside and the harder portion in layers.
- They use bits of soil and excrement to build shelter tubes and to close up breaks in the surface of infested wood.
- If “swarmer” (reproductive) termites have not been seen, the presence of a colony can be determined by probing wood near the foundation or soil or by observing earthen “shelter tubes” on foundation walls or wood.

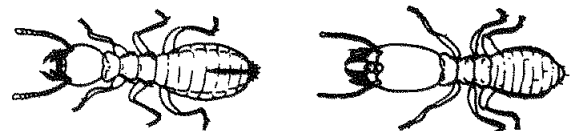

Worker

Soldier

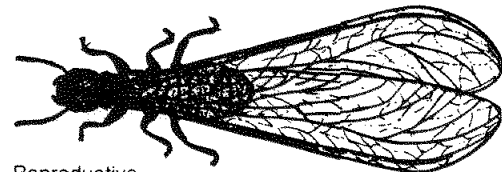

Reproductive

This termite must have wood for food and usually needs soil for moisture. Wood in contact with soil is ideal for termite development. However, termites may build shelter tubes across foundation walls and other surfaces between the wood and the soil. Termites occasionally become established without soil contact when a leaky roof or pipe provides moisture. Infestations may become established under

concrete slabs, garage floors, patios, and filled dirt porches. Termites may then enter the building through structural wood or foundation walls adjacent to the slab. In houses built partly or completely on slabs, termites enter through expansion joints, cracks, and utility openings.

**See page 10a,  
Subterranean Termite  
Entry Points in  
Slab-On-Ground Construction**

Breaking the connection between wood and soil is essential in termite control. This may be done with either a chemical or mechanical barrier.

Soil on both sides of exposed foundation walls and soil surrounding supporting piers should be drenched down to the footing with insecticide. Apply the insecticide by trenching and backfilling or a combination of trenching and rodding.

For outside basement walls (where the footing is deep), dig a V-shaped trench against the wall. It should be deep enough to insure penetration to the footing. After trenching, use a perforated hollow rod to inject insecticide to the footing of the basement wall. When treating concrete block or brick foundation walls, drill them above the grade line and flood all voids with insecticide.

To treat slab-constructed buildings, saturate the soil beneath the slab.

**See page 10b,  
Figure 2-11 and  
Figure 2-12**

Inject insecticide either through holes drilled in the slab or by drilling and rodding horizontally under the slab. Either method must be done carefully to avoid heat ducts, pipes and vapor barriers located under the slab.

Treat filled porches by:

- drilling the slab from the top,
- drilling the porch foundation horizontally at each end next to the building and injecting the chemical by rodding, or
- making openings in the foundation wall, excavating the porch fill immediately under the slab, and drenching the soil with insecticide.

### Dry-Wood Termites

- Directly attack wood and make galleries in it, rather than below ground.
- As they feed, they cut across the ligneous grain of wood, excavating large galleries which are connected by small tunnels.
- They produce hard fecal pellets with six distinct concave surfaces on the sides. These pellets are often pushed out of the infested wood through small holes.

Drywood Termite  
Fecal Pellets



Control dry-wood-termites by fumigating the entire structure with a toxic gas, using a gas-tight tarpaulin. Control small, localized infestations by injecting insecticides through holes drilled into the termite galleries. Furniture and other movable objects may be fumigated in special chambers.

### POWDER-POST BEETLES

There are several kinds of powder-post beetles. The most common are **Lyctid powder-post beetles** and **Anobiid powder-post beetles**. The adults are small (about 1/8 inch long) and usually reddish-brown to nearly black.

Lyctid Powder-Post Beetle

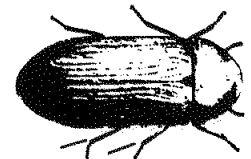
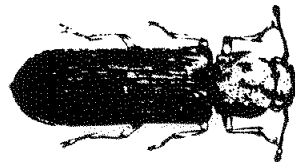

Anobiid Powder-Post Beetle

Small "shot hole" exit openings in the wooden surfaces are a sign of infestation. Slight jarring of the wood causes a fine powder to sift from these holes. When the wood is cut or broken, the interior reveals galleries filled with a finely-packed powder

# SUBTERRANEAN TERMITE ENTRY POINTS IN SLAB-ON-GROUND CONSTRUCTION

## MONOLITHIC SLAB

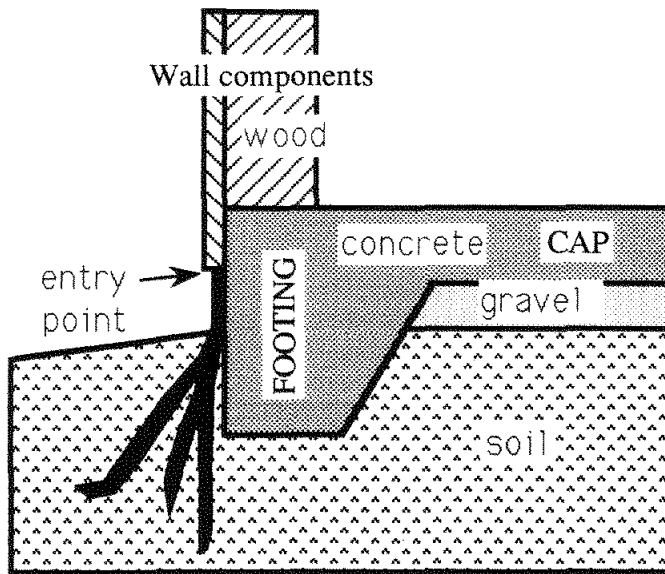

## SUSPENDED SLAB

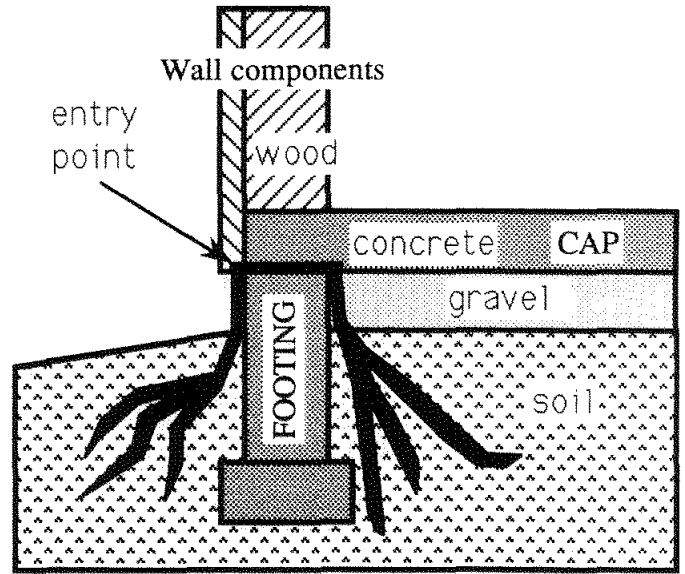

## FLOATING SLAB

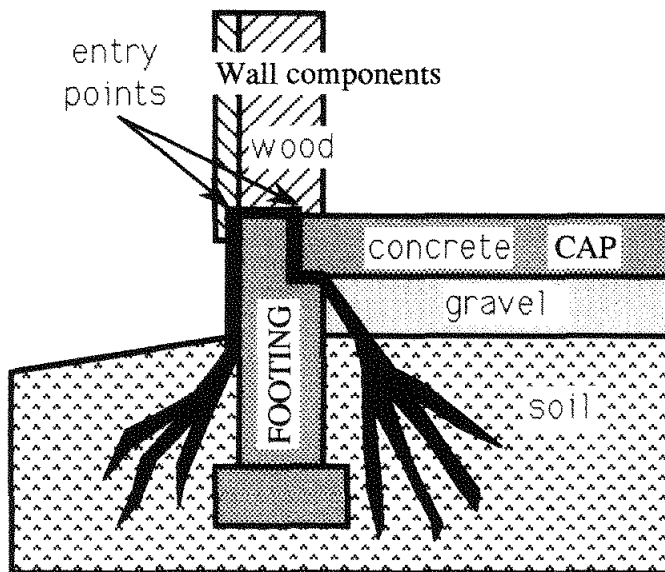

## FLOATING SLAB

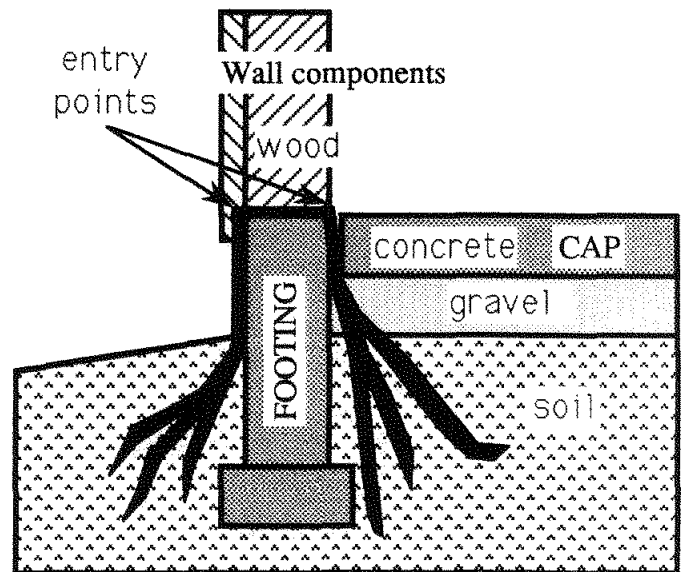

# APPLICATION OF CHEMICAL TO SLAB CONTRUCTION

(ADAPTED FROM USDA)

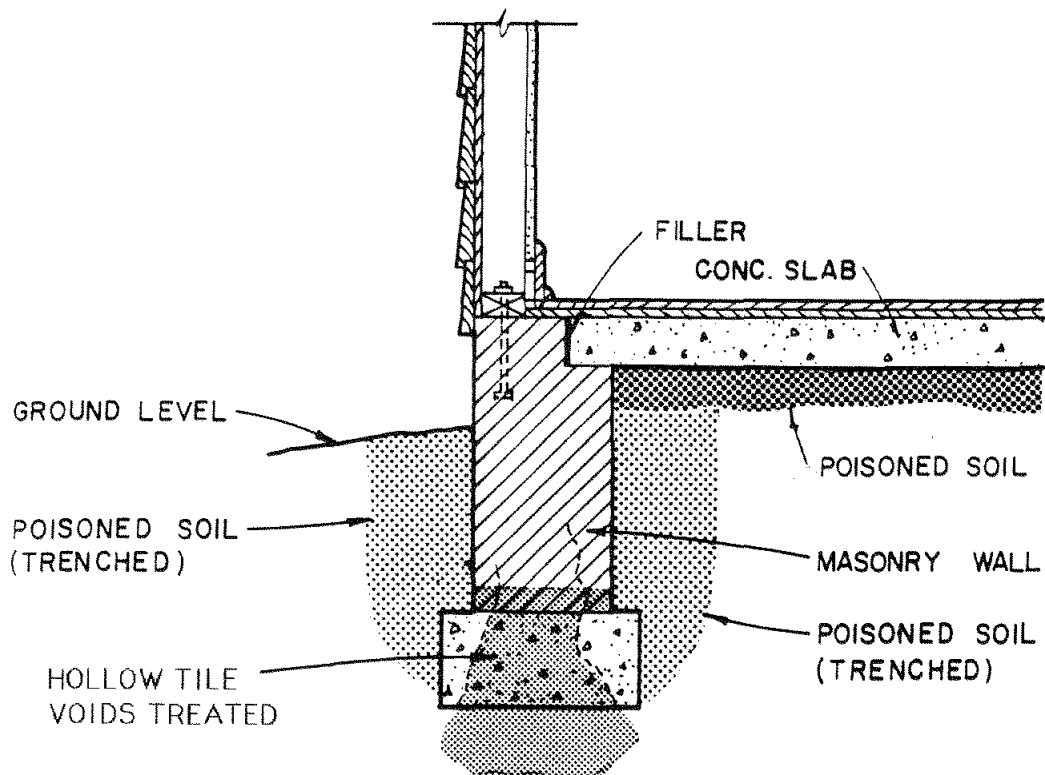

# APPLICATION OF CHEMICAL TO CRAWL SPACE CONSTRUCTION.

*SOIL TREATMENT (1) ALONG OUTSIDE AND (2) INSIDE FOUNDATION WALL;  
(3) AROUND PIER AND (4) PLUMBING.*

(ADAPTED FROM USDA)

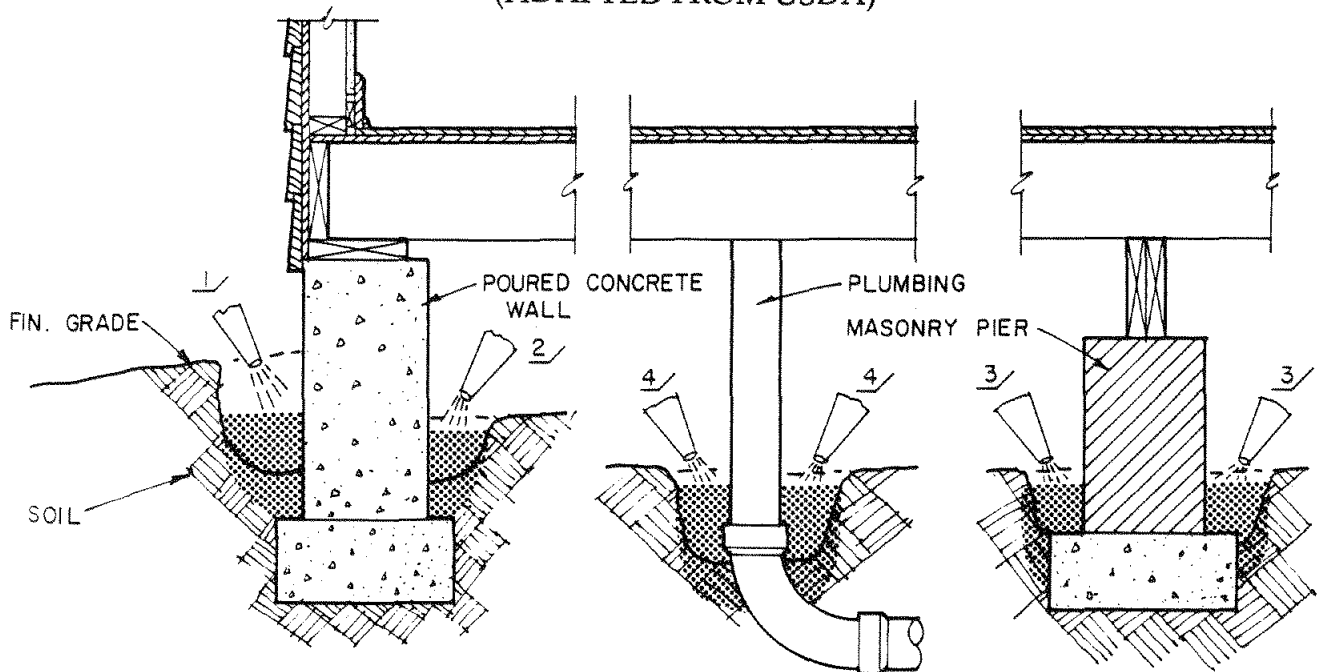

which is produced by the feeding of grub-like larvae. Joists, subflooring, hardwood flooring, sills, plates, and interior trim are the parts of buildings most frequently attacked. Furniture and other wood products also may be damaged.

To prevent infestations or to control existing infestations, wet all surfaces thoroughly with insecticide. Furniture and other movable objects may be fumigated in special chambers.

## LONG-HORNED BEETLES

Long-horned beetles are large ( $\frac{1}{2}$  to 3 inches long) and brightly colored. They have long, thin antennae which may be longer than the body. Eggs are usually laid on unseasoned, rough-sawed timbers or logs. The larvae, called round-headed borers, feed in the wood. They bore large, oval holes as they move through wood.

The only species that requires control in structures is the old-house borer. The adult is about  $\frac{3}{4}$  inch long, grayish-brown to black, and has two white patches on the wing covers. Its galleries have distinctive ripples on the interior surface. The old-house borer usually damages only pine sapwood.

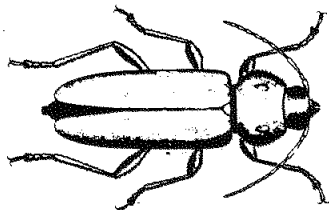

Old House Borer

For control, infested wood must be treated repeatedly with a liquid insecticide. Heavy timbers may be drilled to allow penetration into infested areas. Fumigation under a tarpaulin may sometimes be required.

## WOOD DECAY FUNGI

Severe wood decay occurs only in wood with a moisture content greater than 20 percent. Most wood-rotting fungi grow only on wood which is subject to wetting by rain, roof leaks, plumbing leaks, condensation, or contact with moist soil. Two species, however, can conduct water directly to wood. Fungi take their food from the wood as they grow and reduce the strength of wood, often making it brown and crumbly or white and stringy. Discoloration and powdery mold growth below the

surface of wood should not be confused with decay. The moisture content of the wood may be measured with a moisture meter to accurately determine the need for control.



Wood Decay

Fungicides will not stop wood decay once it has started, though they sometimes slow its progress. The key to complete control of wood decay is to eliminate the source of moisture. This may be done through:

- proper drainage,
- breaking contact between wood and soil,
- ventilation,
- the use of vapor barriers, and
- other good construction practices.

Lumber, pressure-treated with preservative chemicals before use, may prevent attack by wood-destroying fungi.

## STORED PRODUCT PESTS

Most food products may be attacked by insects commonly referred to as "pantry pests". They eat or contaminate the products and may make them unfit for human consumption. They often leave the infested products and move about inside structures. To eliminate infestations, find and destroy infested materials and treat the area where they are stored. Infested materials can be fumigated. Thorough cleaning is essential to remove spilled food to prevent reinfestation.

## GRAIN AND FLOUR BEETLES

The **confused** and **red flour beetles**, the **saw-toothed grain beetle**, and the **cigarette** and **drugstore beetles** are small, reddish-brown insects usually less than  $\frac{1}{8}$  inch long. Their larvae are small and yellowish-white with brown heads. The adults often crawl over infested material and adjacent surfaces. Larvae and adults will be found in the infested material.



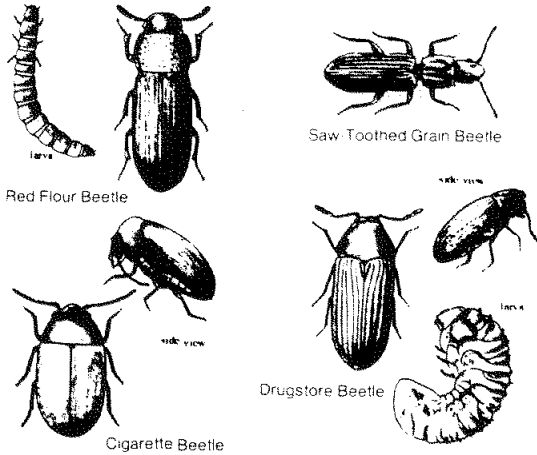

## CABINET BEETLES

Adults have various colored patches of scales on the back and are  $\frac{1}{8}$  inch long. The larvae are fuzzy, light brown to black, and about  $\frac{1}{4}$  inch long. The larval stages do most of the damage. Adults feed mainly on flower pollen outdoors but may feed on stored food products.

## INDIAN MEAL MOTH

The Indian meal moth is a small moth with a wingspread of about  $\frac{1}{2}$  inch. Its forewings have a coppery color on the outer two-thirds and whitish gray near the body. The pinkish-white caterpillars cover the materials on which they feed with loose webbing. The adults fly about near the site of the infestation. The larvae may also leave their food and crawl over adjacent surfaces. This is the most common moth which attacks stored food products.

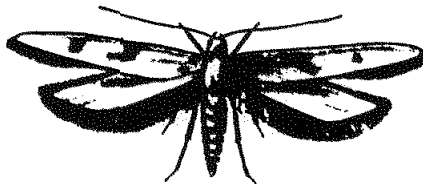

## ANGOUMOIS GRAIN MOTH

The Angoumois grain moth is a tiny moth similar in size and color to clothes moths. It may be seen flying about in the daytime, whereas clothes moths avoid light. The caterpillars develop within whole kernels of grain.

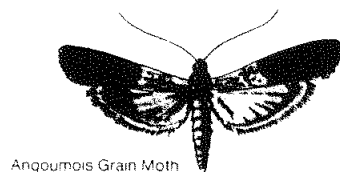

## GRAIN WEEVILS

The granary and rice weevils primarily attack stored whole grain. Adults are reddish-brown to black, about  $\frac{1}{8}$  inch long, and have pronounced snouts. Their larvae are small, white, legless grubs that feed and develop inside individual kernels of grain.

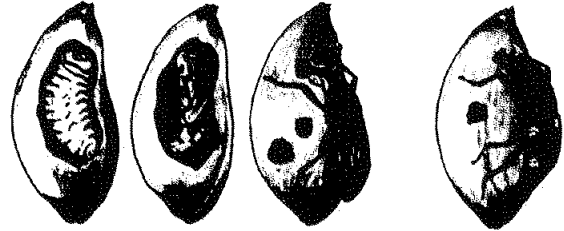

The stages in the life cycle of a weevil are:

- egg,
- larva,
- pupa, and
- adult.

## VERTEBRATES

### RODENTS

- Contaminate and destroy food products.
- Damage furniture, clothing, structures, and other nonedible items.
- Carry diseases and ectoparasites.
- Sometimes bite children and adults.
- Can cause fires.
- Have the ability to coexist with man.

The three most common kinds are:

- Norway, brown, or common rat,
- roof or black rat, and
- house mouse.

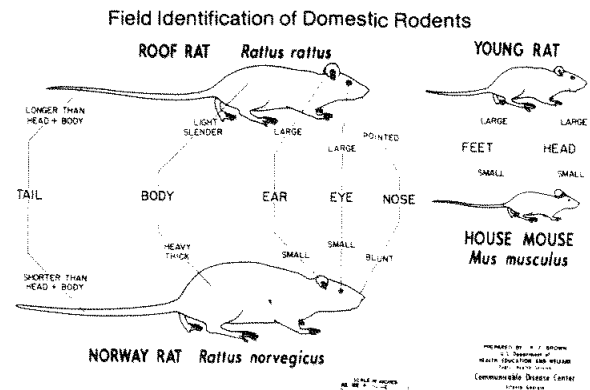

The Norway rat prefers to live in underground burrows, but can climb readily. The roof rat prefers to live in upper portions of a building, but may use burrows. The house mouse lives in any convenient protected space inside or outside.

A rat or mouse control program is based on knowing:

- where they live, feed, and travel, and
- the extent of the infestation.

You must eliminate shelter, food, and water. All entrances the rats or mice use to come and go from buildings must be closed. These preventive measures are the key to successful control. To prevent rodent migration, it is best to poison or trap before making environmental changes.

The two categories of rodenticides are multiple-dose anticoagulants and single-dose toxicants. Each rodenticide has special characteristics, uses, and hazards. Some are highly toxic to humans and pets. Mix, handle, and apply them according to label directions. Keep baits away from people and desirable animals. Place them deep into burrows or use bait stations. Dispose of excess baits and dead animal carcasses frequently.

Mice will eagerly sample new food. Rats, however, usually approach new food with caution. If it tastes bad or makes them sick, they will not eat it again. This is "bait shyness". When using bait for control, use a bait that is fresh and identical to the food the rats are using. If you use a different bait base, pre-bait in the area for a few nights before using a toxic bait. Rats require water to drink. Mice may get water from the food they eat. If all water sources can be eliminated, liquid baits are very effective for rats but only moderately so for mice.

Both rats and mice prefer to run next to walls or other surfaces. Place traps and baits in these runways. Traps may be used with bait, or the trigger device may be expanded and used without bait. Place trigger end of the trap toward the wall. Rats approach new objects cautiously and may be "trap shy".

The mouse investigates any new object or change in its territory, so that changing placement of baits or traps will improve control. Each male house mouse establishes a territory which may not extend

more than 10 feet from the nest. For this reason, baits and traps should be placed no more than 10 to 20 feet apart. To encourage mice to range farther to find food and water, disrupt their environment as often as is practical.

## BIRDS

Birds are pests when they:

- deface and destroy structures, plants, and other property,
- cause disturbances with their noise and droppings,
- contaminate food supplies,
- carry various diseases and ectoparasites.

Birds that may require control are **pigeons, English sparrows and starlings.**

Pigeons are pests in towns and cities where they deface buildings with their droppings and nests.



Sparrows are small birds that often nest in or on buildings.

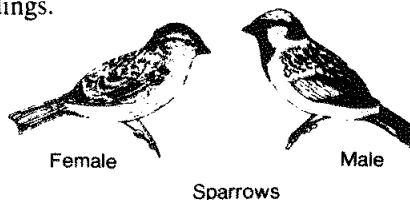

Starlings are pests in the city and rural areas. They are dark, short-tailed birds, intermediate in size between pigeons and sparrows. They are objectionable when they roost in large numbers near human dwellings.

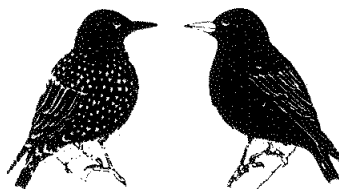

**NOT  
ESTABLISHED  
IN  
HAWAII**

Sanitation is the first step in control. Remove food, water, and habitat. Control methods include building out, removing food, and using repellents, traps, or avicides.

Building out involves using new construction features or modifying existing features so that birds cannot roost or nest. Repellents include various devices or substances installed on buildings, such as noise makers (distress calls), charged wires, and repellent glues or jellies. Traps are often used successfully in pigeon control, especially when prebaited for a few days. Population reduction includes shooting (where permissible) and the use of avicides. Chemical control is probably the most effective method. Follow label directions closely.

## BATS

Bats are night flying mammals. They have leathery membranous wings. They roost in attics, hollow walls, chimneys, caves, barns, hollow trees and other similar places. In addition to the general nuisance and odors associated with bat infestations, they harbor ectoparasites that may attack man. They carry and are subject to rabies. Bats can best be controlled by closing all openings through which they may enter structures to roost. Carefully observe bats leaving roosting areas. Locate and close entrance openings.

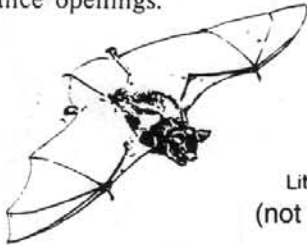

Little Brown Bat  
(not established in Hawaii)

Only one bat, a native, is established in Hawaii. The 'ope'ape'a, Hawaiian Hoary Bat, lives on Kauai, Maui, and Hawaii. It is not a pest. In fact, harming this rare bat or its habitat is a violation of the federal Endangered Species Act.

## SKUNKS

Skunks create nauseating odors, damage lawns, harbor ectoparasites, and are subject to rabies. They may enter buildings. Entrances should be closed when the skunk is outside or it may be baited to trap outside the building for removal to a remote site.

**NOT ESTABLISHED  
IN HAWAII**



## SQUIRRELS

Squirrels of various species may enter buildings and be a nuisance or do damage to the structure. They may bite when cornered. They carry ectoparasites. Squirrels can be controlled by closing openings, by using repellents or by using live traps to remove them to remote areas. Where it is permitted, squirrels may be shot.

**NOT  
ESTABLISHED  
IN HAWAII**

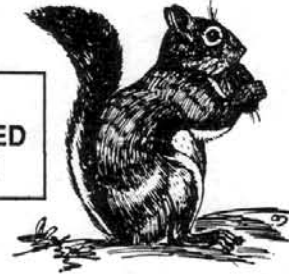

## MOLES

Moles burrow underground and rarely come above ground. Their burrows deface lawns and they may damage the roots of ornamental plants as they search for earthworms and insects. Traps specifically designed for mole control may be useful in some situations.



**NOT  
ESTABLISHED  
IN HAWAII**

## SNAKES

Snakes may find their way into and around buildings. Most of them are not poisonous but may frighten humans and may bite when disturbed. Removal of food and hiding places will usually force snakes out of an area. Keep snakes from getting inside by closing all points of entry.

Except for a harmless blind burrowing snake about the size of an earthworm, snakes are probably not established in Hawaii. But larger ones such as non-poisonous Garter snakes and constrictors have been reported and captured in Hawaii. If they become established and begin breeding, they could cause serious problems. For example, the Brown Tree Snake established itself and began breeding on Guam around 19\_\_\_. Since then, the snake killed off much of the island's wild birds. It also attacked domestic chickens and pets, and even caused electrical outages by short circuiting power lines.

Help control unwanted snakes in Hawaii by reporting them to the State Department of Agriculture or the State Department of Land and Natural Resources. (Your local zoo or animal shelter could refer you to the proper authorities.) Don't buy illegal snakes for pets; this encourages sellers to import them into Hawaii. Snakes, as well as lizards, turtles, alligators and other exotic pets, which escape or are set free into the wild can become serious problems for Hawaii's wildlife, pets, plants, and people.

## WEEDS

Weeds around structures may need control because:

- they create a fire hazard,
- they harbor insects or rodents, and
- they shorten the life of metal fences and buildings.

Weed control can be done by:

- Non-selective vegetation control (bare ground)—residual, broad-spectrum herbicides used to kill all plant growth and prevent new growth for a season or more. Used where reduction of fire hazard is important.
- Short-term vegetation control—herbicides are used at rates that give a good knockdown of existing vegetation and retard the regrowth. Used where bare ground is not necessary.
- Selective weeding—control of certain plants without permanent injury to desirable plants.
- Chemical trimming and pruning—use of contact herbicides to give narrow bands of controlled weeds around desirable plants or buildings. Often used to give mowing strip around trees or under guard rails.
- Mechanical or cultural control—use of hoes, blades, fertilization, landscaping, competitive planting, or other nonchemical methods to control unwanted vegetation.

Herbicides can be applied as preemergence or post-emergence treatments. A herbicide can affect plants by:

- killing the plant or plant parts that it contacts,
- killing when the herbicide is absorbed by foliage and transported throughout the plant, or
- killing when roots absorb the herbicide dissolved in soil moisture and translocated throughout the plant (may last a season or more in the soil but requires rain, irrigation, or mechanical incorporation—discing—for activation in the soil).

Factors affecting herbicide performance:

- Type of weed—all herbicides are selective to some extent and will fail to kill some types of plants. Some herbicides will work better on grasses and some will work better on broadleaf plants. Perennial weeds can often grow back from their extensive root systems and will require multiple treatments or special techniques and herbicides. Brush control may be particularly difficult but can be done in the following ways:

Foliage absorbed—usually applied in the summer.

Basal stem—applied to soil around stems or clumps in late winter or early summer.

Stump treatment—application of herbicides to freshly cut stump.

Dormant cane treatment—applications of fuel oil during winter.

- Type of soil—sand or other soil low in clay and organic matter will not absorb the herbicide as much, so lower amounts will give equivalent results. Leaching will be more of a problem. Soils high in clay or organic matter will absorb some of the herbicide. More herbicide and more rainfall is usually necessary for effective control.
- Rainfall—too much rain soon after a contact herbicide is applied can nullify its effectiveness but the same amount of rain might facilitate the action of a root-absorbed herbicide. Rainfall may also wash herbicides away from the target plants, injuring nontarget plants and animals.
- Growth stage of plant—foliage-absorbed herbicides will usually work only when the plant is actively growing. Preemergence herbicides must be applied before the weeds have emerged or a contact herbicide will have to be added to kill those that have emerged. Where selective herbicides are used, it is important that the nontarget plants be healthy.
- Sunlight—some herbicides can be nullified if they remain on the soil surface too long before a rain washes them in.

Choose equipment for the type of herbicide treatment desired.

The pump will usually be a high volume (10 gpm or more) but low pressure (50–100 lbs psi). Nozzles will usually be selected to give uniform coverage with large droplets to minimize drift. Mechanical agitation in the tank is required if wettable powders will be used.